



TALEX Sp. z o.o.
ul. Dworcowa 9c
77-141 Borzytuchom
tel.: +48 59 821 13 40
e-mail: biuro@talex-sj.pl
www.talex-sj.pl

USER MANUAL

WARRANTY

SPARE PARTS CATALOGUE

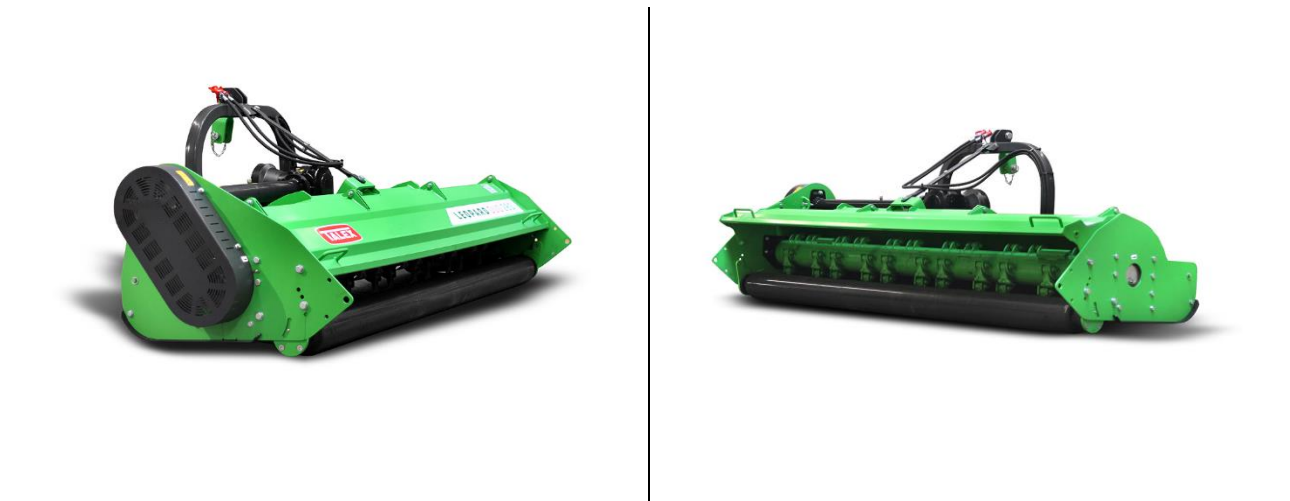

All-purpose flail mower

LEOPARD

200; 250; 280

Borzytuchom 2023

Revision 08

TRANSLATION OF THE ORIGINAL MANUAL



NOTE!

Before using the machine, please read thoroughly this Instruction Manual and observe the safety instructions contained herein.

The instruction manual is the basic equipment of the machine!

Keep the Instruction Manual in a safe place, where it should be accessible to the machine operator during an entire lifespan of the machine.

In the event of its loss or damage, the user must acquire a new copy from the machine dealer or manufacturer.

In the event the machine is sold or made available to another user, the Instruction Manual must be attached with the declaration of conformity for the machine.

The manufacturer reserves its copyrights to the Instruction Manual.

Copying, processing of the User Manual and its parts without the manufacturer's permission is strictly prohibited.



Table of Contents

1. Introduction	4
2. Machine identification.....	5
3. Rules of safe operation	6
3.1 User safety	6
3.2 Safety signs on the machine and their meaning	9
3.3 Hazards associated with the operation of the shredder	10
4. Intended use of the machine.....	11
5. Description of the machine	12
5.1 Equipment and accessories	13
5.1.1. Basic.....	13
5.1.2. Additional	13
5.1.3. Technical specification	14
6. Machine operation.....	15
6.1. Mounting – installation of the shredder.....	15
7. Operation and maintenance	16
7.1 Adjustment of the belts tension	16
7.2. Cover adjustment.....	17
7.4. Maintenance after work	19
7.5. Lubrication	20
7.6. Post-seasonal maintenance	21
7.7. Scrapping, environment	21
8. Spare Parts Catalogue	22
8.1 Shredder – general view.....	23
8.2. Body	24
8.3. Wheel	25
8.4. Bearing housing	26
8.5. Shaft assembly diagram.....	27
8.6. Working shaft with cutting blades / flails.....	28
8.7. Drive system.....	29
8.8. Drive system – belt transmission.....	30
8.9. Drive system – Extension tube.....	31
8.10. Suspension	32
8.11. Front curtain	34
8.12. Belt cover guard.....	35
8.13. Internal traction shaft	36
8.14. External traction shaft.....	37
8.15. Skids.....	38
9. Warranty Card	39
10. Declaration of Conformity.....	41

1. Introduction

Before the first use of the shredder, you must thoroughly read and understand this instruction manual, and follow all the instructions contained herein.



NOTE!

Read the instruction manual before use

This instruction manual contains a description of the hazards that can occur in case of non-compliance with safety rules during operation and maintenance of the shredder. The Instruction Manual specifies precautionary measures to be taken to minimize or avoid risks.

This manual also contains principles of correct use of the shredder and specifies the maintenance operations to be performed.

If you do not understand any information contained herein, please contact directly the manufacturer.



NOTE!

This symbol warns you of a hazard. The warning symbol indicates an important hazard information given in the Instruction Manual. Please read the information, follow the instructions and exercise particular caution.



2. Machine identification

Each shredder has its rating plate, containing the most important identification data. The rating plate is located on the machine in such place, that it is easy to find and to read.



www.talex-sj.pl

biuro@talex-sj.pl

+48 59 82 113 40

Sp. z o.o.
ul. Dworcowa 9c
77-141 Borzytucho
POLAND



Nazwa/Name:	ROZDRABNIACZ UNIWERSALNY
Typ/Type: 200	Nr seryjny/Serial No.: 000001
Masa/Weight: 481 KG	Rok produkcji/ Year of production: 2023

Manufacturer's rating plate includes:

- full name of the manufacturer,
- the symbol of the shredder,
- weight,
- date of manufacture.
- serial number of the shredder,
- the CE marking,
- quality control sign,



3. Rules of safe operation

3.1 User safety

The shredder can only be used by adults, who have learnt its operation and read this instruction manual, and are properly qualified. The shredders should be operated with all necessary precautions, in particular:

- Apart from this Instruction Manual, observe also general rules of health and safety at work.
- Observe warning symbols placed on the machine.
- It is strictly forbidden, to operate the machine by persons under the influence of alcohol or other intoxicants.
- Never allow the vehicle towing the shredder to be driven by a person other than the shredder operator, and under no circumstances allow any other persons to be on the vehicle, or by the machine, during its operation.
- The shredder may be operated by an operator licensed to drive the vehicle onto which the shredder has been mounted, in line with the recommendations of its manufacturer.
- The operating position of the operator, while working with the shredder, is the cabin of the vehicle to which the machine is attached.
- Please note that on the shredder there are many places that could cause injury (sharp edges, protruding structural elements, etc.). During the operation an increased caution should be kept when moving near the said critical places and the following personal protective equipment must be used:
 - protective clothing,
 - protective gloves,
 - safety shoes.
- It is forbidden to carry persons or objects on the machine.
- Persons who have not read the Instruction Manual are not allowed to operate the machine.
- The person operating the shredder should be provided with a first-aid kit containing measures for first aid, along with instructions regarding their use.
- When driving a vehicle with the attached, but not working shredder, ensure the safe transportation height of ~ 0.3m.
- Take special care when driving on public roads, and comply with the applicable road traffic regulations.
- When driving on public roads, obligatorily use the electric marker lamps lighting of the vehicle, with prior check for its functionality, visibility and cleanliness. On the machine or on the rear of the vehicle a triangular plate must be fitted, distinguishing low-speed vehicles. Make sure the retroreflectors and warning signs on the structural components of the machine are clean and visible.
- **Adjust the transport speed according to the road surface conditions, without exceeding 20km/h.**
- Do not leave the vehicle with the shredder on a hillside or other sloping surfaces, without securing the vehicle from rolling down. The shredder must be lowered to the ground. Put wedges under the wheels of the vehicle.
- The shredder must be adjusted to working height, during its attachment to the vehicle. The position adjustment of the equipment during its operation is possible from the vehicle cab without the need to leave the cab by the operator.



- Any preparations, fitting, dismantling or adjustment can be performed only after the drive has been switched off, the engine stopped, the vehicle immobilized and when all the moving parts of the machine have stopped.
- After first hour of operation, check the status of all separable connections, including screws.
- The shredder should be kept on a flat, level, paved surface, out of the reach of bystanders and animals.
- Exercise caution during the mounting and dismounting of the shredder, and pay particular attention to the structural elements through which the cutter is connected with the vehicle.
- Before using the shredder you must check the condition of shredder and of the vehicle it is attached to. The vehicle and the shredder unit must be in good technical condition. Any worn or damaged parts must be replaced immediately.
- The shredder must be equipped with all the safety guards (provided by the manufacturer), preventing access to any moving parts. The guards must be complete and fully operational.
- Before beginning to work with the shredder, familiarize yourself with the way it operates, occupational safety rules and recommendations for maintenance and adjustment procedures, by reading this instruction manual.
- The weight of the shredder mounted on the vehicle may affect the manoeuvrability. In such situation exercise particular caution.
- The Instruction Manual must be kept with the machine. If you loan the machine for use, ensure that it is in good technical condition, and that it is complete with the Instruction Manual.
- Do not attach additional transport means to the shredder.
- During commissioning, check the machine functions and make the initial adjustments, without a load.
- Three-point hitch suspension system assembly protection of the shredder with pins should be made only using the typical secure cotter pins. Do not use other securing methods.
- Follow the procedure laid out in Chapter 6 to carry out inspections of the condition and completeness of the machine cutting tools with regard to their natural wear. Operation and maintenance.
- When commissioning and transporting the shredder, inspect its technical condition to check for damage.
- It is forbidden to stand under the raised shredder, as it may result in being crushed by the structural elements.
- When adjusting, keep your fingers and limbs away from the structural parts of the machine.
- The operator of the vehicle coupled with the shredder must ensure that no person **can approach the machine during its operation within the distance of 50 m from the running** shredder.
- Ensure suitable visibility when u-turning, reversing or manoeuvring the machine, or ensure assistance from a properly trained person.
- Do not stay between the vehicle and the shredder when the vehicle engine is running.
- Working on slopes exceeding 10% is not allowed.
- Exercise particular caution when working on slopes.
- When making turns and returns turn off the PTO (power take-off shaft).
- It is forbidden to operate the machine in close proximity of public squares (parks, schools, etc.) or on stony grounds, to prevent the risk of stones and other objects being thrown into the air.









- Do not allow the PTO service speed to exceed 540 rpm, while the driving speed must be adjusted according to the type of work being done.
- Using a damaged or incomplete jointed telescopic shaft is prohibited. In particular, it is strongly forbidden to work without guards on moving parts.
- Never leave the vehicle unattended when the engine is running. Before leaving the driver's seat (the cab), lower the machine to the ground, turn off the engine of the vehicle, remove the ignition key, and apply the handbrake.
- Avoid wearing unbuttoned, hanging parts of work clothes during the operation, assembly, disassembly or adjustment. Keep them away from components that can catch them.
- After work it is recommended to clean and wash the shredder in the wash fitted with a sewage treatment plant or a settler to neutralize the resulting waste water.
- Storage, warehousing of the machine should be carried out in places protected from outsiders and animals by eliminating the risk of accidental injury, on a flat, paved surface, under a roof.
- In case of failure, immediately turn off the drive transmitted from the vehicle.

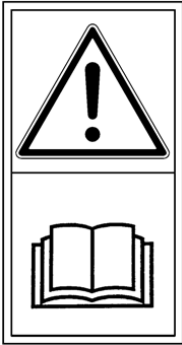
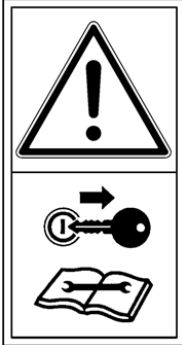





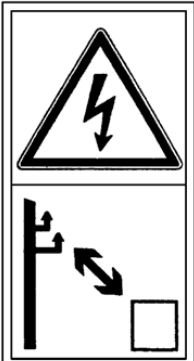

Failure to follow the above rules may be dangerous for the operator and bystanders and can cause damage to the shredder.

The operator is responsible for any damage caused by failure to adhere to the above rules.

3.2 Safety signs on the machine and their meaning

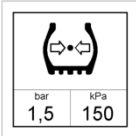
 <p>1.0 - Prior to using the machine, read the Instruction Manual</p>	<p>C.2.26</p>  <p>1.1 - Switch off the engine and remove the ignition key before any servicing or maintenance procedures</p>	<p>C.2.36</p>  <p>1.2 - Keep a safe distance from the machine. Do not allow unauthorised persons within the range of 50 m from the machine</p>
<p>+A.8.19</p>  <p>1.1.1 - Warning, belt transmission. Use extreme caution. Drawing-in of hand and arm.</p>	<p>+A.8.7</p>  <p>1.1.2 - Warning, possibility of being drawn-in by the machine</p>	<p>C.2.7</p>  <p>1.5 - Do not stand near the lift strands when controlling the lift</p>
<p>C.2.20</p>  <p>1.6 - Do not open or remove safety guards when the engine is running</p>	<p>C.2.30</p>  <p>1.7 - Keep a safe distance from power lines</p>	<p>C.2.44</p>  <p>1.8 - Avoid exposure to liquids flowing under pressure. Read the Instruction Manual and learn about the operation procedures</p>

<p>A.6.2 + B.2.6</p>  <p>1.2.1 – Keep a safe distance from the machine. Crushing of toes or foot – Force applied from above</p>	<p>C.2.27</p>  <p>1.4 - Do not ride on platforms or ladders</p>	 <p>2.1 - Lifting points on the mower during handling</p>  <p>2.5 – Warning message about pressure in the hydraulic system</p>
 <p>2.5.1 – Warning about the pressure present in the tyres</p>	 <p>2.3 – Use protective coverall</p>	 <p>2.4 – Use safety gloves</p>

3.3 Hazards associated with the operation of the shredder

No.	Risk	Risk source (cause)	Protection measures against risks
1	Overloading the locomotor system (physical load)	Working in a standing position, inclined-forced position, walking, moving objects	Read and understand the Instruction Manual; do workplace training in carrying weights standards for the manual handling, correct methods of lifting and carrying loads, getting other persons' help, and the use of handling devices such as jacks and winches.
2	Fall on the same level (tripping, slipping, etc.)	Uneven terrain, messy environment - objects lying and standing around, cables lying on communication roads, slippery surfaces	Suitable footwear, levelled surface, maintaining caution, maintaining order, familiarising with the instructions manual
3	Hitting protruding parts of the machine	Machine and its surroundings	Proper positioning of a machine, safe space to move around, proper organisation of work, paying attention, reading the Instruction Manual
4	Struck by moving objects	Crushed plants, incidental part of the turf, stones thrown out by the machine	Maintaining caution, marking out the danger zone, prohibiting walking around the working machine, prohibiting being at a distance of less than 50m from the working machine, use of personal protective equipment - helmet, safety glasses, reading the Instruction Manual
5	Sharp, dangerous edges	Protruding parts of the machine structure, use of hand tools	Personal protective equipment – safety gloves, buttoned up work clothes, exercising special attention
6	Belt transmission systems	Fast moving transmission pulleys and belts, rotating jointed telescopic shaft, no covers on the movable parts	Ban of moving, approaching and making adjustments on the running machine, exercising caution, using shields of moving parts, reading the instruction manual
7	Weight of the suspended stationary machine	Improper mounting or coupling, wrong position of the machine, improper operation, leaving the suspended machine on a tractor	Exercising special attention, use of personal protective equipment - safety footwear, safety gloves, secure position of the machine, help of others, use of lifting jacks and hoists, reading the Instruction Manual

8	Microclimate - variable weather conditions	Work carried out in varied weather conditions	Suitable working clothes, beverages, creams with sun screens, proper rest, reading the Instruction Manual
9	Noise	Too high rotational speed of the machine, damaged, loose or vibrating parts	Operation of the machine in good technical condition, inspections on a regular basis, proper rotational speed, reading the Instruction Manual

4. Intended use of the machine

The All-purpose Shredder is designed to destroy the remainders of plant crops and to shred the cut-down tree and shrub branches, it is perfect for mulching meadows and pastures. It is a machine suspended on tractors with 40 ÷ 95 horsepower (e.g. the C360 MF235, MF55) powered from the PTO of the tractor by a jointed telescopic shaft to the power input shaft of the machine.

Mounting the machine to the vehicle is possible via the three-point hitch suspension system mounts.

The working element is the spinning shaft with the pivotally mounted blades or hammers. This unit is driven from power input shaft, through angular transmission and belt transmission.

Complying with the requirements for the use of the machine, its operation and repairs strictly according to the manufacturer's guidelines is the condition for the use of machine as intended. The machine should be used, operated and repaired only by persons familiar with its specific characteristics, who have learnt the rules of conduct prescribed by the occupational health and safety regulations.

The manufacturer offers a wide range of agricultural machinery. It can also provide professional advice in terms of choosing the right equipment for your needs.



Any doubts concerning the device's intended use should be resolved by contacting its manufacturer. Selection of the appropriate product and knowing the range of its intended use will contribute to the occupational safety.

5. Description of the machine

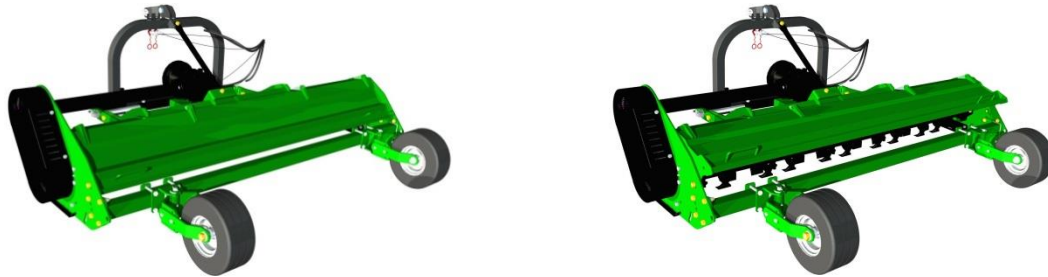

Figure 1. Overview of the Leopard machine

The all-purpose shredders are made of two main construction elements. The first component is the **supporting framework with the transporting unit**, made of welded steel parts to form a rigid and robust structure. The second component is the **drive unit of the shredder** which consists of an angular gear 1: 3, belt transmission, bearing shaft and hammers (or blades) mounted on the shaft holders. The drive unit of the shredder starts the power input shaft of the machine. Everything is enclosed in safety guards. The machine has adjustable wheels or a shaft leading the machine during work. In addition, the LEOPARD shredders incorporate a hydraulic system to move the machine relative to the three-point linkage. This allows a very precise positioning of the machine during operation. The shredders are equipped with a front curtain preventing stones and hard objects from being thrown forward.



Figure 2. LEOPARD shredder – hydraulic shift of the machine

5.1 Equipment and accessories

5.1.1. Basic

The basic elements of the shredder include the following:

- Wheels or traction shaft
- Instruction Manual
- Warranty Card



The shredder is not supplied with a portable warning light or a triangular slow vehicle warning sign. These elements can be purchased separately from the manufacturer or in a farming equipment depot. Each user of the machine should have a fully functional triangular slow vehicle warning sign. Failure to install these elements during transport may result in an accident. The machine user is responsible for the damage resulting from the accident.

5.1.2. Additional

1. The PTO shaft is CE marked.

Attention!

ALL OPTIONAL ELEMENTS OF THE MACHINE ARE AVAILABLE FROM THE MANUFACTURER FOR AN ADDITIONAL CHARGE.



All maintenance and servicing works should be done with the switched off engine of the vehicle, released pressure and stopped rotations, and with both, the vehicle and machine, properly secured.



Avoid contact with oil!
Use the personal protective equipment: protective clothing, footwear, gloves and goggles.



The power take-off shaft should be operated and lubricated strictly according to the operating instructions provided by the manufacturer of the shaft.



5.1.3. Technical specification

Table No. 1

TECHNICAL DATA

<i>No.</i>	<i>Description</i>	<i>UoM</i>	<i>Parameter</i>		
1.	Type	-	200	250	280
2.	Hitch type	-	Mounted, 3pt linkage		
3.	Shredding width	[mm]	2000	2500	2800
4.	Min. power requirement	[HP]	40	50	75
5.	Number of working shafts	[pcs.]	1	1	1
6.	Number of blades	[pcs.]	64	80	92
7.	Number of flail hammers	[pcs.]	32	40	46
8.	Shredding height	[mm]	Horizontally acc. to pre-sets		
9.	Tractor three-point hitch class	-	II		
10.	Set-up of the shredder for shipment	-	Horizontally		
11.	PTO shaft speed	[RPM]	540		
12.	Working efficiency	[ha/h]	1.6	2	2.24
13.	Tyre pressure in wheels	[BAR]	1.5		
14.	Working speed	[km/h]	3 - 8		
15.	Transport speed	[km/h]	Up to 20		
16.	Number of operators	[pcs.]	1		
17.	Overall dimensions				
	Length	[mm]	1270	1270	1270
	Width	[mm]	2200	2700	3000
	Height	[mm]	1000	1000	1000
18.	Weight, incl. wheels	[kg]	517	574	632
19.	Weight, incl. roller	[kg]	481	545	604

6. Machine operation

6.1. Mounting – installation of the shredder



Make sure that the connecting parts of both, the vehicle and the machine, are suitably adjusted to each other.

In case of any doubt, always ask the vehicle or the machine manufacturer.

I. Installation of the suspension system of the vehicle and the machine.

The machine is mounted on a three-point hitch suspension system of the tractor, vehicle. In order to facilitate aggregating the bottom tie-rods should be located at the height of ca. 350 mm. After hitching the machine, the length of the top coupler must be adjusted in such a way that the position of slides is parallel to the ground. The bottom tie-rod hitch chain should be adjusted in such a way that the lateral tilts of the machine are minimal. Depending on the three-point hitch suspension system type, make sure the original safety elements are present. Each time the mower is mounted on the vehicle, check the connecting elements, i.e. pins and plugs, for wear. In case of wearing out replace them with new ones.

II. Installation of the machine's drive shaft.

After mounting the machine on the three-point hitch suspension system, mount the jointed telescopic drive shaft onto the PTO of the tractor and the power input shaft of the machine and lift the support to the upper position.

III. Installing power hydraulic system

The Leopard shredder, which incorporates a hydraulic control system, is fitted with connections, which should be connected to the connections of the vehicle's supply system using hydraulic hoses. Make sure the lines are routed correctly and the hydraulic connections are clean.



Use only the original jointed telescopic shaft for the shredder drive, marked with the CE sign and PTO and power input shaft canopies. Check if the latches are securely clamped after sliding the articulated telescopic shaft caps onto the PTO (take-off) and PTO (take-on) shafts cones.



For power hydraulics, use suitable and tight hoses with matching couplings. To dismantle the machine, follow the above instructions in a reverse order, exercise particular caution when disconnecting the mechanical system between the machine and the vehicle.

7. Operation and maintenance

All the machine operations can be performed by the operator of the vehicle, to which the machine is attached, providing he/she has proper authorization to operate this vehicle.

Operating the machine is permissible only after reading the instruction manual.

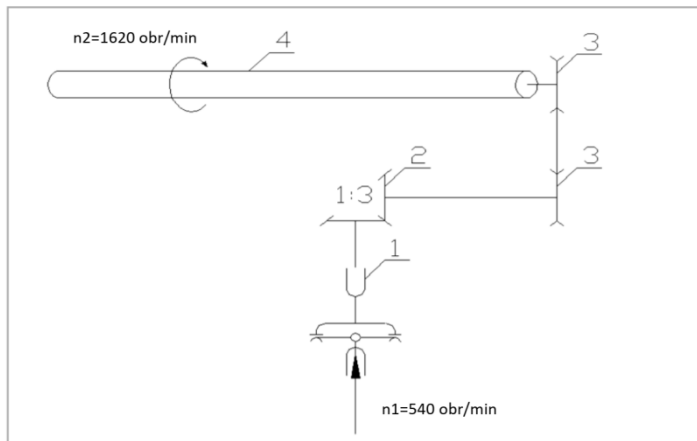

1. Power take-off shaft
2. Angular gear box
3. Belt transmission
4. Shaft

Figure 3. Shredder drive diagram

7.1 Adjustment of the belts tension

The adjustment of the transmission belts tension is done with the machine turned off and the vehicle engine switched off; see Fig. 4. The optimal tension of the belts – under the pressure of 100 N ($\sim 10 \text{ kG}$) the belt bends 1.5 - 2.5 cm. The successive activities need to be carried out in the following manner:

1. Remove the belt transmission shield,
2. Check the condition and tension of the V-belts (replace the damaged ones with new),
3. Loosen the nuts (1),
4. Tighten the bolt (2) checking the tension of belts,
5. Secure the bolt with the lock nut,
6. Tighten the nut (1),
7. Install the metal transmission shield,

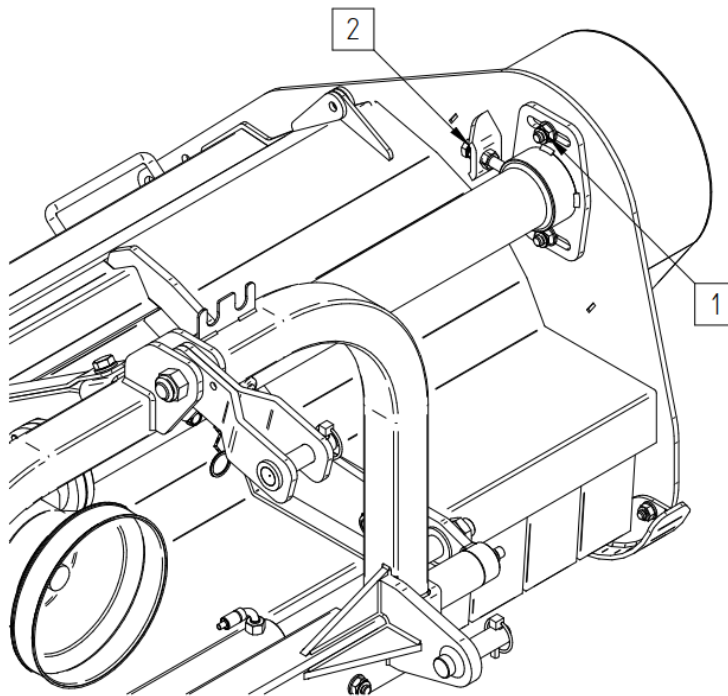

Figure 4. Adjustment of the transmission belts tension

7.2. Cover adjustment

The All-purpose LEOPARD shredder has an additional function which allows a greater spread of the shredded plant parts. The machine is equipped with an openable cover.

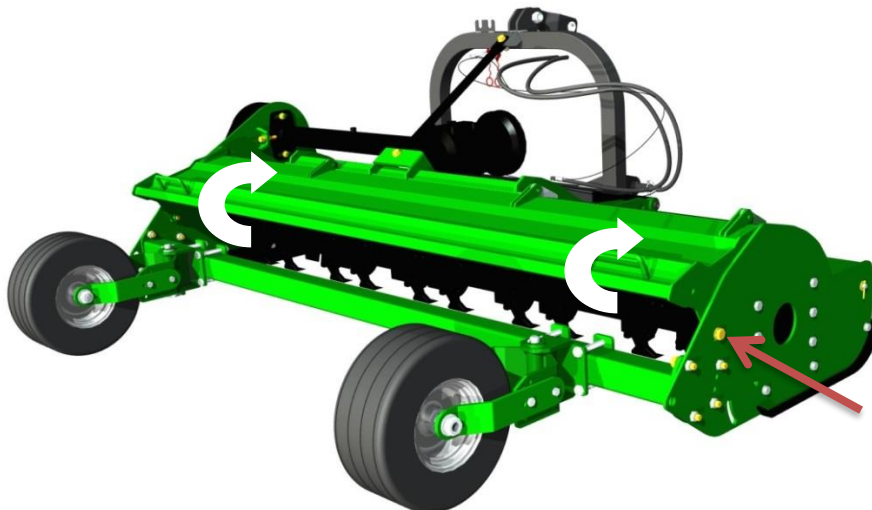

Figure 5. Lifted cover of the LEOPARD shredder

The liftable cover is on one side mounted pivotally to the frame of the shredder, on the other side it is fixed with bolts. Lift the shield and fasten it in the open position with the fastening bolts after unscrewing the bolts on both sides.

7.3. Replacement of the blades, hammers

Depending on the customer's requirements, the working shaft is equipped with the appropriate equipment in the form of shredding tools. These are 3.4 blades or 3.8 hammers (described in Section 7.6) Fig.6.

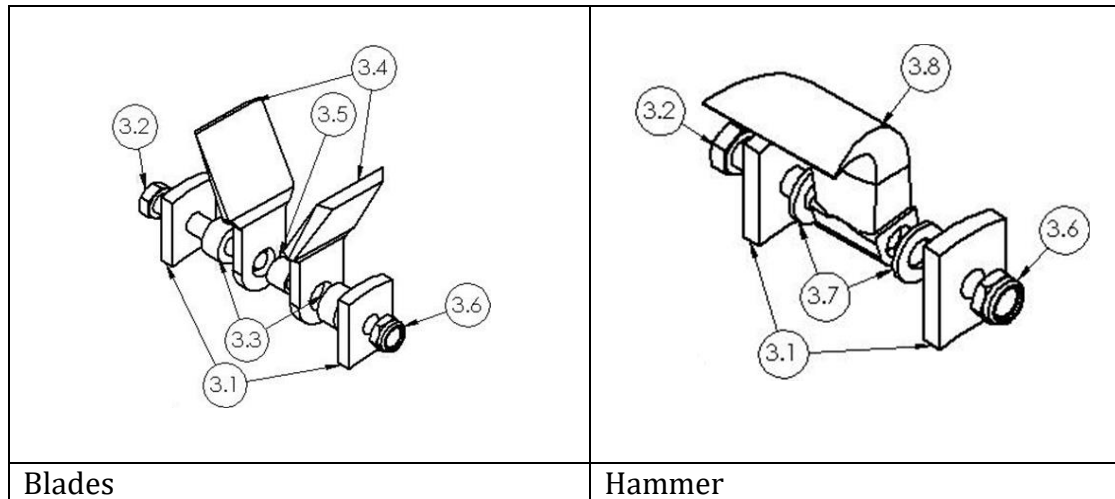

Figure 6. Installation of blades and hammers



The shredding tools must be replaced after discovering defects, noticeable signs of wear, blunting of the cutting edges, missing blades or hammers, or excessive play of the mounted tools.

Table No. 2

MAXIMUM PLAY OF THE SHREDDING TOOLS

Play	rated [mm]		allowable [mm]	
	Blade	Hammer	Blade	Hammer
Transverse axial	0.2	0.3	0.5	0.6
Longitudinal axial	0.1	0.2	0.4	0.6

The shredding tools must be replaced in compliance with the specific safety rules.

1. Use only the original and functional parts for the cutting units
2. The replacement must each time include the full set of tools. You must remember about the uniform distribution of the rotating masses, to ensure the uniform wear of the tools.
3. The bolt connections need to be replaced with new ones each time the tools are replaced, paying attention to the durability 8.8 of the bolt and the self-locking nut.
4. When tightening the bolt connection, pay attention to the free (without excessive play) rotation of the tool in relation to the bolt axis.

7.4. Maintenance after work

Each time your work has been completed, clean the machine and position it on a flat and hard ground. For a wheeled shredder, it is recommended to use the position as shown in Fig. 7 for easier assembly and disassembly.

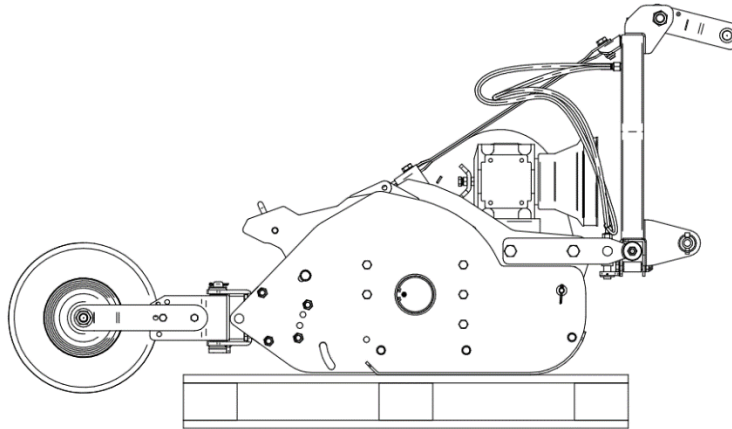

Figure 7. Positioning the machine on a wooden pallet after work.

Carry out an inspection of connections between the parts and units. Replace damaged and worn out parts with new ones. Check all the bolt connections and tighten the loose ones, according to Table 3 showing tightening torque values for bolts and nuts.

All safety signs on the machine and the triangular plate distinguishing slow vehicles should be kept clean.

TIGHTENING TORQUE VALUES FOR BOLTS AND NUTS

Durability	6.8	8.8	10.9	12.9
Metric thread	Tightening torque [Nm]			
M5	4.5	5.9	8.7	10
M6	7.6	10	15	18
M8	18	25	36	43
M10	37	49	72	84
M12	64	85	125	145
M14	100	135	200	235
M16	160	210	310	365
M18	220	300	430	500
M20	310	425	610	710
M22	425	580	820	960
M24	535	730	1050	1220

At least once a year check the level of oil in the angular gear unit. Use the GL 4 80W90 gear oil.

It is also necessary to check the tension of V-belts, replace the damaged ones with new, adjust the whole set in accordance with the Manual 6.1 Adjustment of the belts tension.

It is important to check the play of axes and shafts. Replace the axis or shaft bearings (always in pairs) with new ones, according to the catalogue of spare parts, in case a noticeable play is discovered. All bearings have two-sided dirt protection rings.

7.5. Lubrication

To ensure the correct performance of the machine, it must be thoroughly and properly lubricated according to the diagram - Fig. 8.

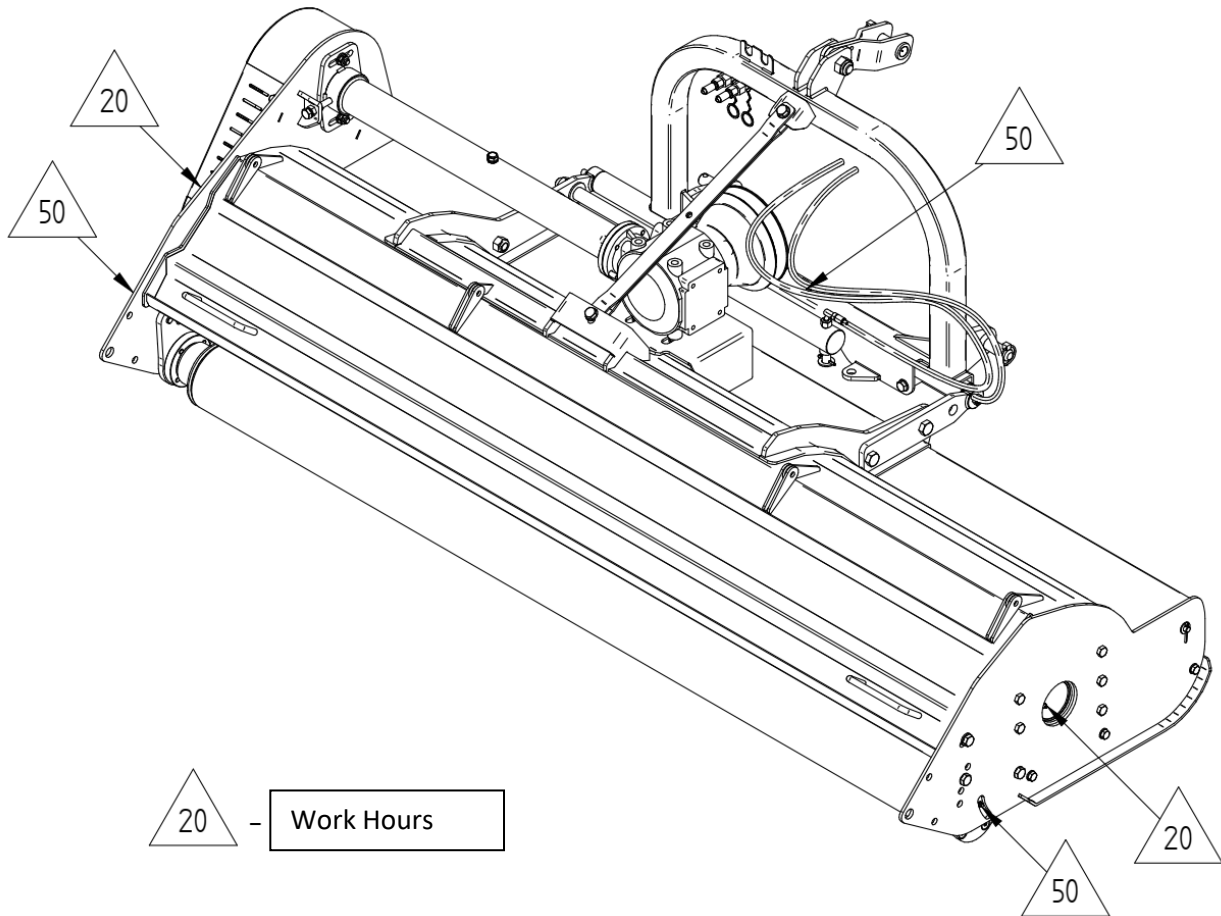

Figure 8. Lubrication diagram

All points marked with a triangle on Fig. 8, and equipped with ball grease fittings, should be filled with ŁT43 solid grease by means of a lubricator. Lubricate the jointed telescopic shaft after removing it from the machine. Lubricate the telescopic part of the shaft at least after 8 hours of operation - when the shaft is entirely moved apart and impurities have already been cleaned.



7.6. *Post-seasonal maintenance*

Includes all activities specified in the item "Things to do after your work has been completed". In addition, the machine should be stored under shelter, on a flat and hard surface. Attention should be paid to the tightness of paint coat. If there are any defects in the coat, clean the spot and apply a new protective coating.

7.7. *Scrapping, environment*

In the event the machine is worn to the extent which prevents its further use, it should be scrapped. This also applies to regular repairs and replacement of damaged parts. Clean the machine thoroughly before scrapping. Drain oils from the machine and have the machine decommissioned. Next, disassemble the machine by segregating its parts based on the applied materials. Segregated parts should be transported to a scrap yard or disposed of.

The machine is 100% environmentally friendly. 97% of the materials used in the production process are recyclable. Worn machine parts must be disposed of in line with the local environment protection regulations. Prevent oil leakage throughout the period of use of the machine, as oil may pollute the environment.

8. Spare Parts Catalogue

Each order form should include the following:

- Address of the buyer,
- exact shipping address (place where machine is located or other means for delivery collection),
- terms of payment,
- serial number and year of production of the tedder (according to the plate located on the machine),
- spare part number,
- spare part name,
- number of parts ordered.



Spare parts must be ordered at the points of sale of the machines or from the manufacturer. Use only the original spare parts provided by the manufacturer, to guarantee safe and reliable operation of the machine. The use of not original spare parts or parts, which have been repaired, will void the warranty.

The manufacturer reserves its right to make changes in the construction of parts presented on the particular assembly drawings in this spare parts catalogue. Such changes may not always be updated in the User Manual and in the spare parts catalogue. Individual drawings may differ from the actual look of the parts.

TALEX Spółka z ograniczoną odpowiedzialnością

ul. Dworcowa 9C
77-141 Borzytucho
Tel.: +48 59 821 13 40
www.talex-sj.pl
e-mail: biuro@talex-sj.pl

8.1 Shredder – general view

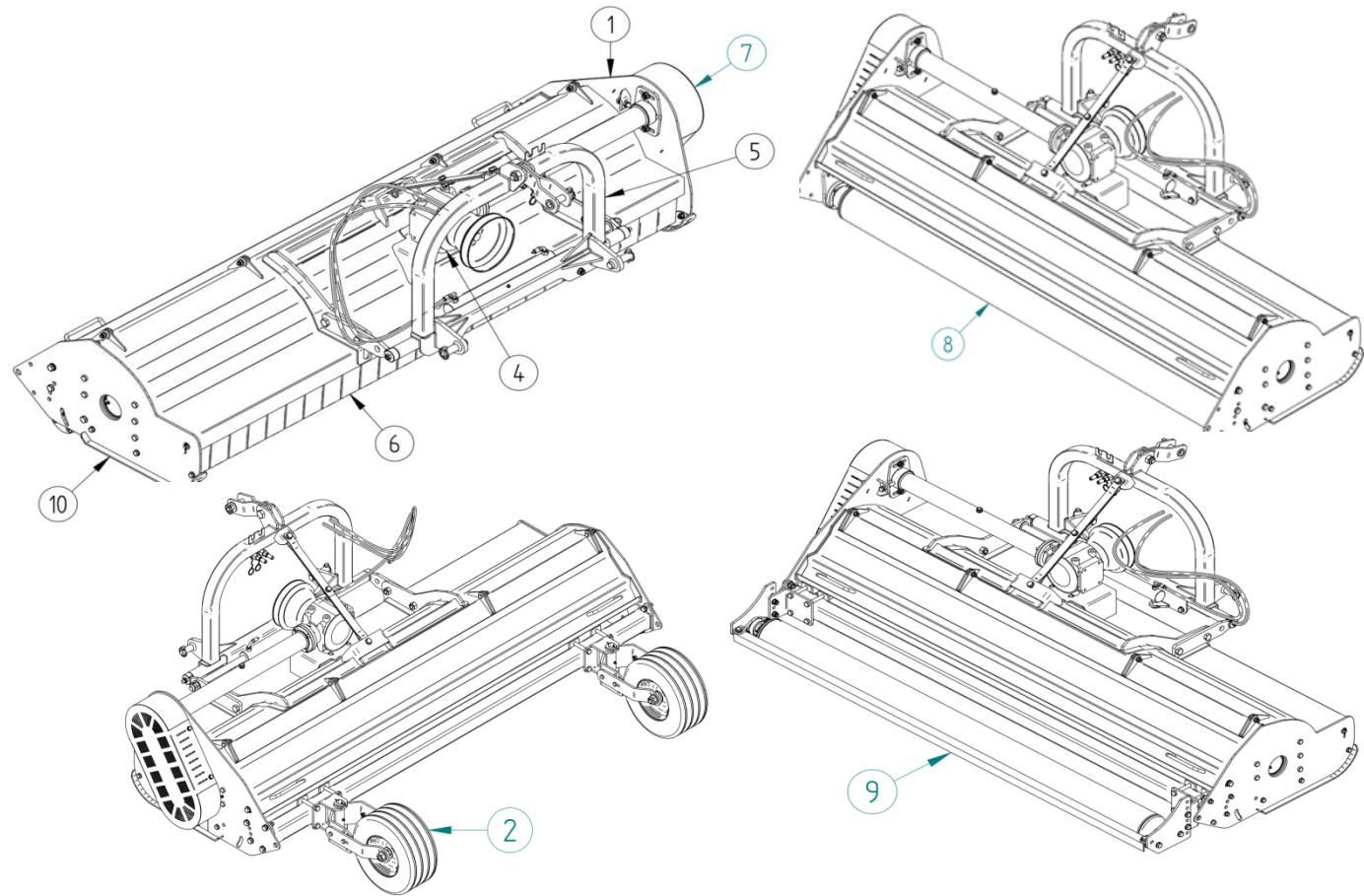

Figure 9. Diagram of the shredder

GENERAL VIEW		
Item	Description	Index No.
1.	Body with the cover	Section 8.2
2.	Wheels	Section 8.3
3.	Working shaft (inside the body)	Section 8.4 - 8.6
4.	Drive system	Section 8.7 - 8.9
5.	Suspension	Section 8.10
6.	Front curtain	Section 8.11
7.	Belt cover guard	Section 8.12
8.	Internal traction shaft	Section 8.13
9.	External traction shaft	Section 8.14
10.	Slides	Left
		Right
		Section 8.15

8.2. Body

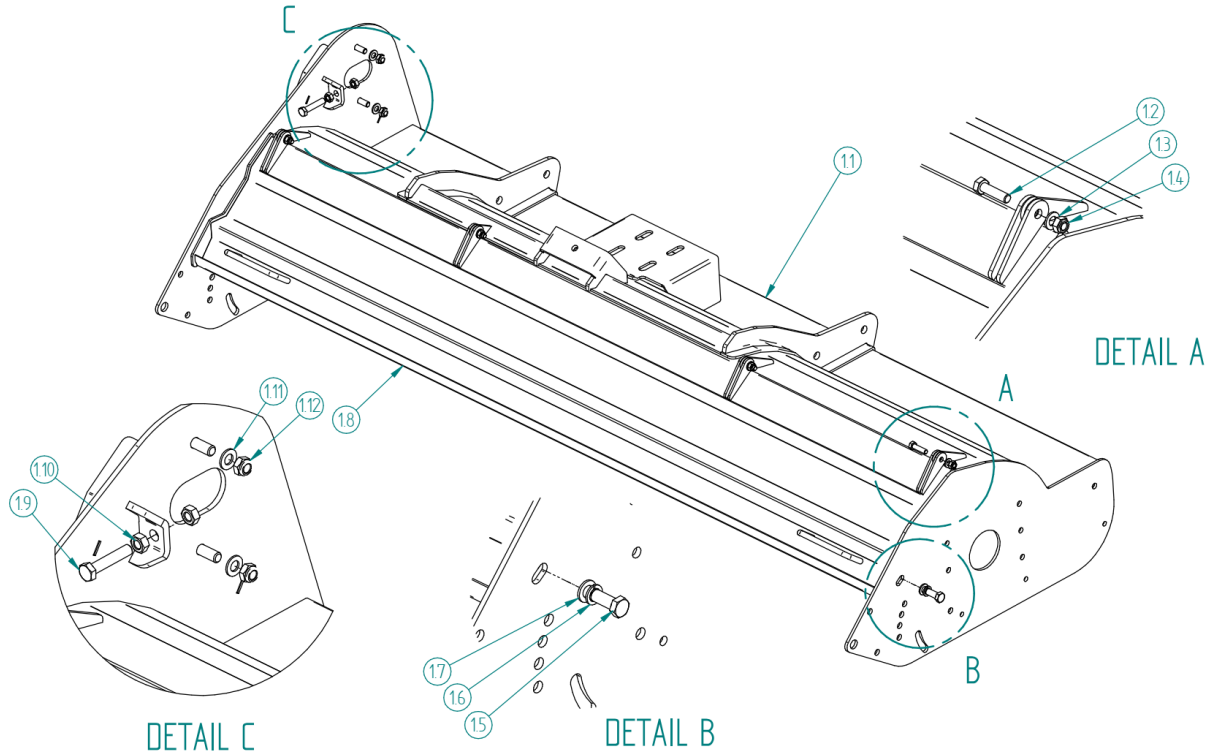

Figure 10. Body

BODY			
Item	Description	Index No.	Quantity
1.1	Body	L-2000	P001464
		L-2500	P001473
		L-2800	P001482
1.2	Bolt M12x45 GALV 8.8 full thread DIN 933	T000758	4
1.3	Washer M12 GALV DIN 125	T000458	4
1.4	Self locking nut M12 GALV 8 DIN 985	T000291	4
1.5	Bolt M16x40 GALV 8.8 full thread DIN 933	T000685	2
1.6	Spring washer M16 GALV DIN 7980	T000453	2
1.7	Washer M16 GALV DIN 125	T000460	2
1.8	Mobile cover	L-2000	P001452
		L-2500	P001470
		L-2800	P001479
1.9	Bolt M14x70 GALV 8.8 full thread DIN 933	T000770	1
1.10	NUT M14 GALV 8 DIN 934	T000269	2
1.11	WASHER M14 GALV DIN 125	T000459	2
1.12	SELF LOCKING NUT M14 GALV DIN 985	T000293	2

8.3. Wheel

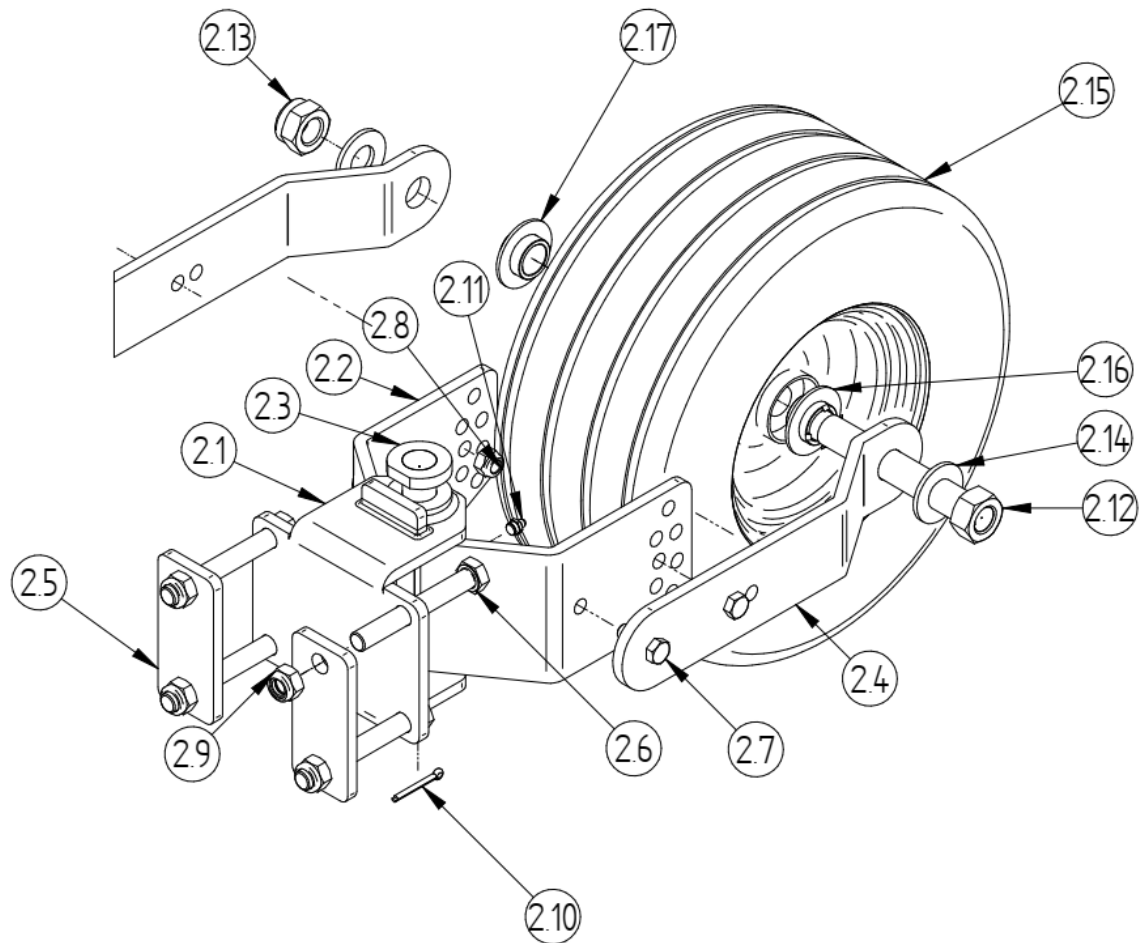

Figure 11. Wheels

WHEEL		P280130 (full)	
Item	Description	Index No.	Quantity
2.1	Swinging arm base	P280132	1
2.2	Wheel swinging arm	P280141	1
2.3	Wheel swinging arm pin	P280138	1
2.4	Swinging arm	P280145	2
2.5	Tie plate	P290135	2
2.6	Bolt M16x120 8.8 GALV	T000774	4
2.7	Bolt M12x35 8.8 GALV	T000756	4
2.8	Self locking nut M12	T000291	4
2.9	Self locking nut M16 GALV	T000294	4
2.10	Split linchpin 5x40	T000985	1
2.11	Grease nipple M10x1	T000643	1
2.12	Wheel axle 25x200	P280146	1
2.13	Self locking nut M24	T000290	1
2.14	Flat washer M25 GALV	T000464	2
2.15	Wheel 16x6.5-8	T000092	1
2.16	Wheel axle bushing	P280149	1
2.17	Wheel axle bushing	P280152	1

8.4. Bearing housing

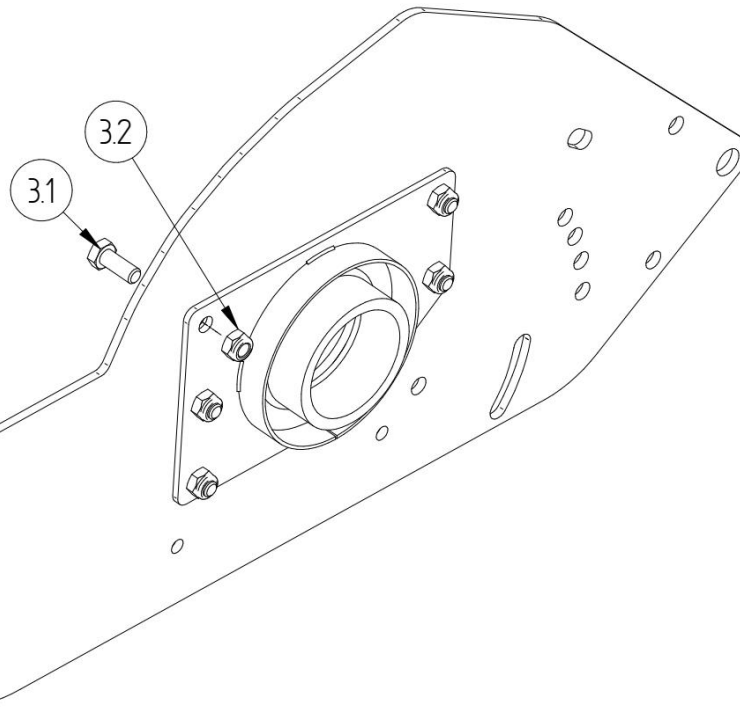

Figure 12. Mounting the bearing housing

MOUNTING THE BEARING HOUSING			
Item	Description	Index No.	Quantity
3.1	Bolt M14x35 8.8 GALV	T000766	5 per housing
3.2	Self locking nut M14	T000293	5 per housing

8.5. Shaft assembly diagram

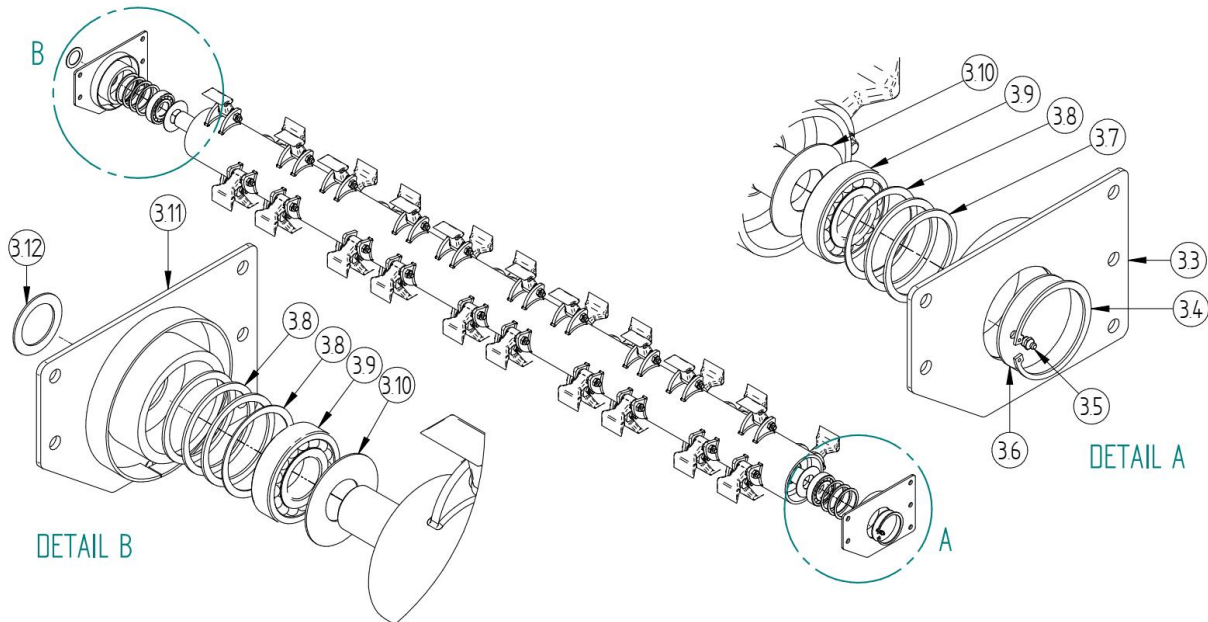

Figure 13. Shaft assembly diagram

SHAFT ASSEMBLY DIAGRAM			
Item	Description	Index No.	Quantity
3.3	Bearing housing, right	P360175	1
3.4	Circlip 100W	T000405	1
3.5	Grease nipple M10x1	T000643	1
3.6	Bearing cover on the housing side	P280085	1
3.7	Spacer ring	P280086	as
3.8	Spacer ring	P280087	needed
3.9	Bearing 1309	T000209	2
3.10	Bearing cover on the shaft side	P280084	2
3.11	Bearing housing, left	P001487	1
3.12	Oil thrower ring	T000330	1

8.6. Working shaft with cutting blades / flails

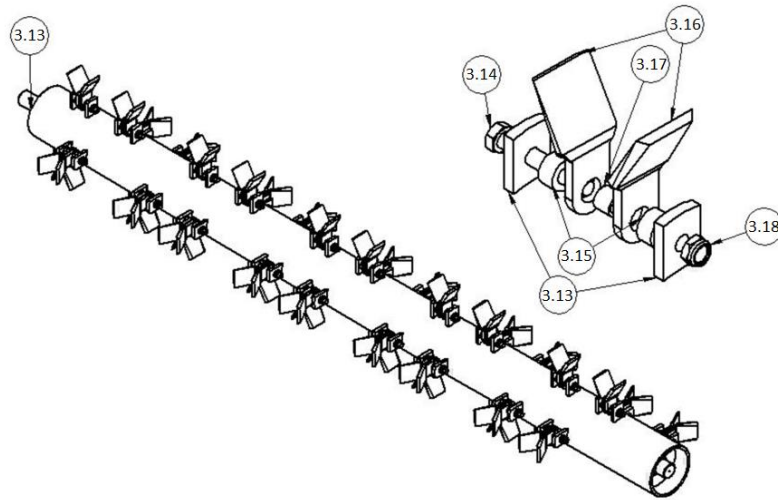

Figure 14. Working shaft with cutting blades

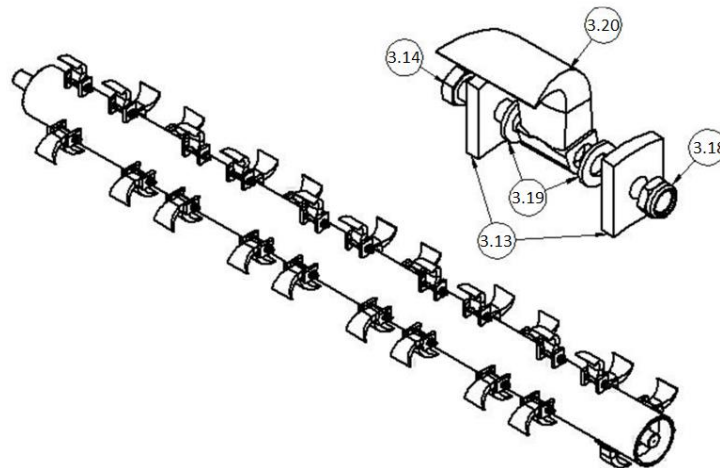

Figure 15. Working shaft with flails

WORKING SHAFT WITH CUTTING BLADES / FLAILS					
Item	Description	Index No.	Quantities depend on size		
			L-2000	L-2500	L-2800
3.13	Working shaft	P230070	1	0	0
		P280070	0	1	0
		P310070	0	0	1
3.14	Bolt M14x90 8.8 GALV	T000772	32	40	46
3.15	Blade bushing	P280081	64	80	92
3.16	Blade	T000307	64	80	92
3.17	Blade bushing	T000861	32	40	46
3.18	Self locking nut M14 GALV	T000293	32	40	46
3.19	Spacer	P000097	64	80	92
3.20	Flail	T000225	32	40	46

8.7. Drive system

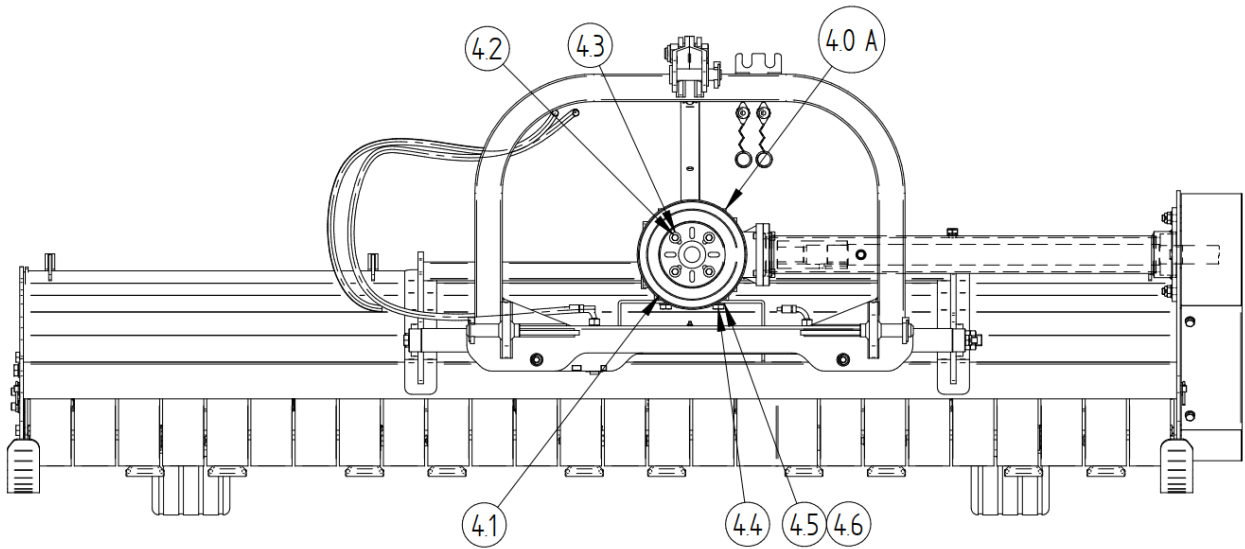

Figure 16. Gearbox

GEARBOX			
Item	Description	Index No.	Quantity
4.0 A	Gearbox	T000501	1
4.1	PTO guard 16548	T000368	1
4.2	Bolt M8x16 8.8 GALV	T000803	4
4.3	Washer M8, large	T000443	4
4.4	Bolt M16x30 8.8 GALV	T000779	4
4.5	Spring washer M16 GALV	T000453	4
4.6	M16 regular washer	T000460	4

8.8. Drive system – belt transmission

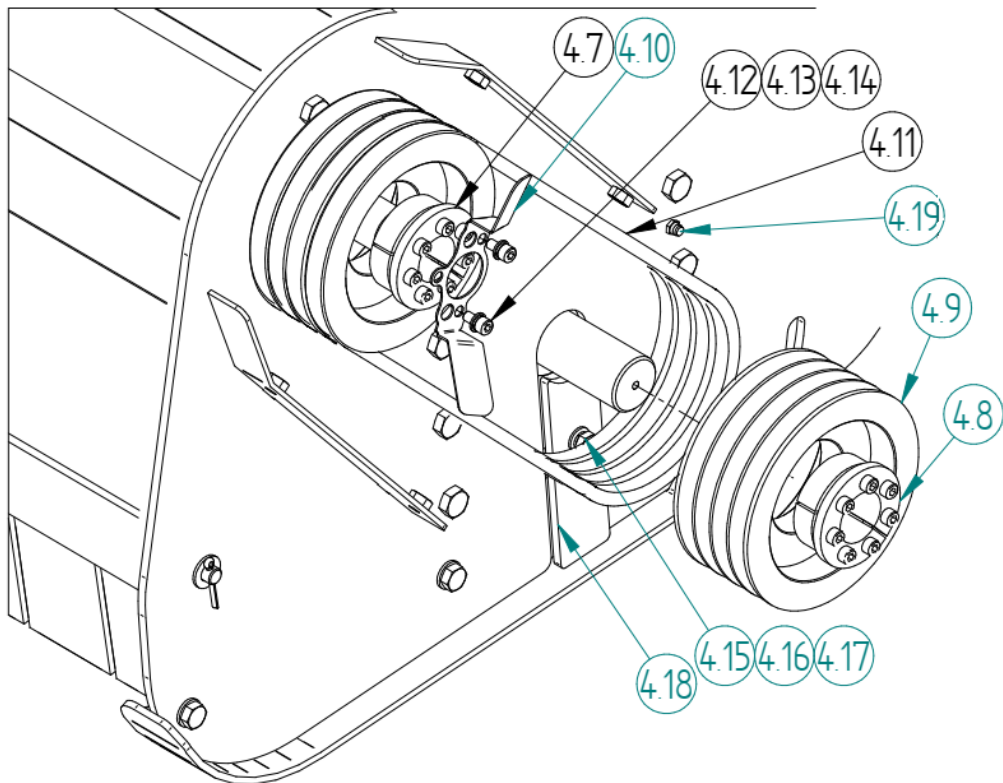

Figure 17. Belt transmission

BELT TRANSMISSION			
Item	Description	Index No.	Quantity
4.7	Clutch 225-40/80	T000681	1
4.8	Clutch 225-45/80	T000682	1
4.9	Pulley, dia 189	T000102	2
4.10	Fan	P001429	1
4.11	V-belt B 1320	T000387	4
4.12	Socket bolt DIN 912 M8x16, GALV	T000733	2
4.13	Spring washer M8 GALV	T000455	2
4.14	Simple washer M8 GALV	T000471	2
4.15	Bolt M10x25 GALV 8.8 full thread DIN 933	T000740	1
4.16	Simple washer M10 GALV DIN 125	T000456	1
4.17	Spring washer M10 GALV DIN 7980	T000450	1
4.18	Side cap	P001439	1
4.19	Grease nipple M10x1 DIN 71412-A	T000643	1

8.9. Drive system – Extension tube

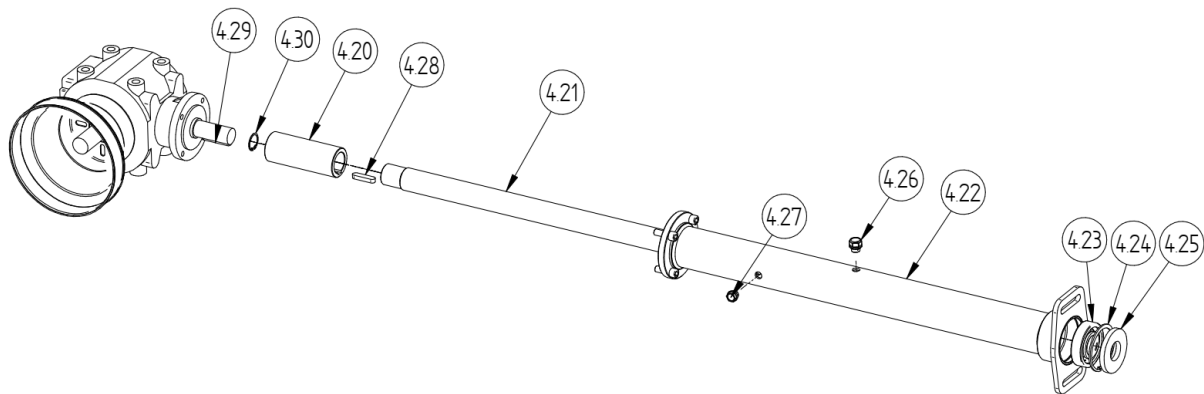

Figure 18. Extension tube

Extension tube			
Item	Description	Index No.	Quantity
4.20	Power transmission connector	P280113	1
4.21	Extension tube drive shaft	L-2000	T001423
		L-2500	T001424
		L-2800	T001425
4.22	Drive shaft shield	L-2000	P240113
		L-2500	P280114
		L-2800	P320113
4.23	Bearing 6308	T000210	1
4.24	Circlip 90W	T000429	1
4.25	Seal 40*90*10	T000882	1
4.26	Aerating filter 3/8	T000329	1
4.27	Drain plug 3/8	T000820	1
4.28	Prismatic inlet 12x8x50	T000949	1
4.29	Prismatic inlet 10x8x63	T000948	1
4.30	Circlip 33W	T000425	1

8.10. Suspension

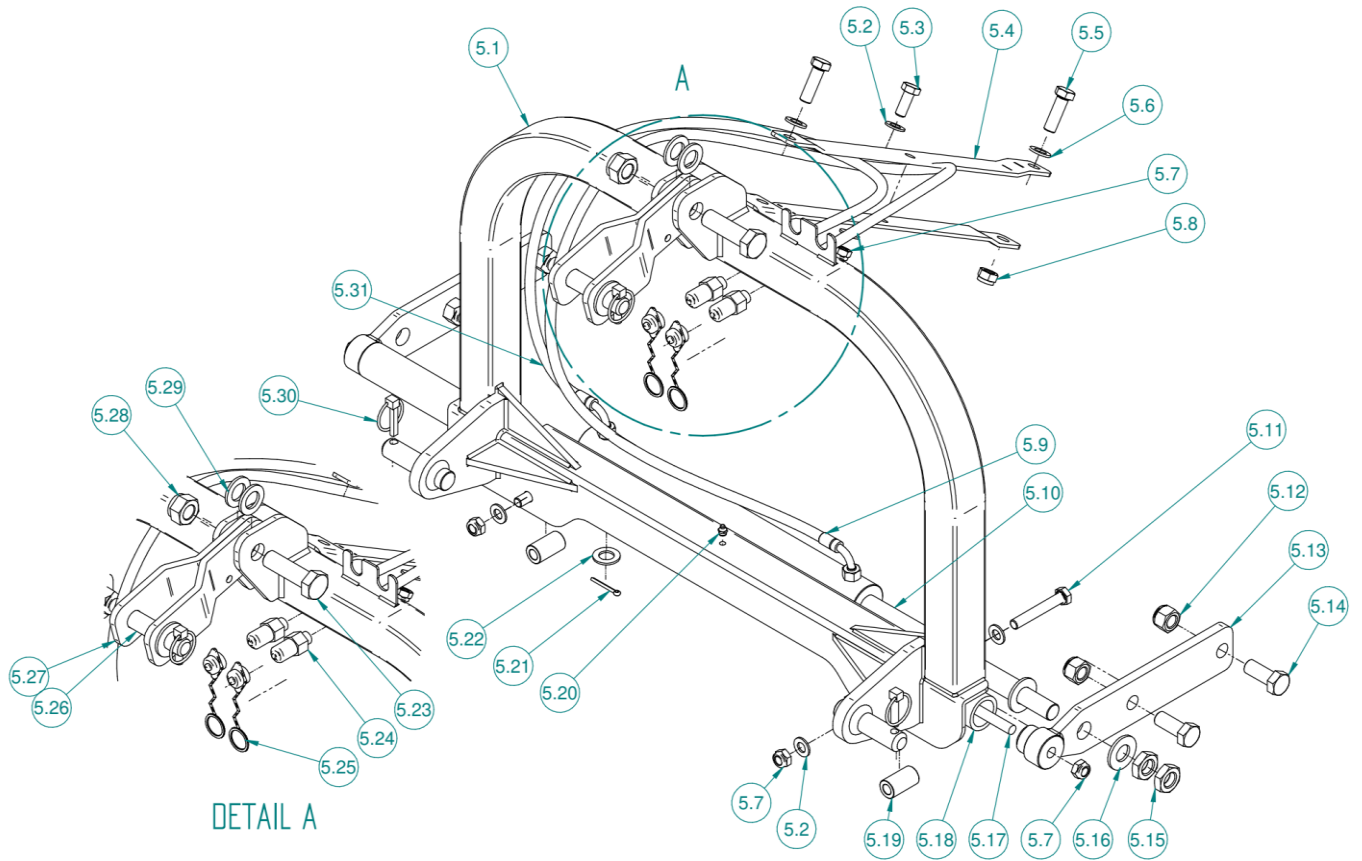

Figure 19. Suspension frame



SUSPENSION FRAME			
Item	Description	Index No.	Quantity
5.1	Suspension	P001427	1
5.2	Simple washer M14 GALV DIN 125	T000459	6
5.3	Bolt M14x35 GALV 8.8	T000766	1
5.4	Transporting connector	P001421	2
5.5	Bolt M16x50 8.8 GALV	T000781	2
5.6	Simple washer M16 GALV DIN 125	T000460	2
5.7	Self locking nut M14 GALV	T000293	4
5.8	Self locking nut M16 GALV	T000294	2
5.9	Hose AA90/221/8L 2610	T000524	1
5.10	Hydraulic cylinder	T000034	1
5.11	BOLT M14x90 - 10.9 partial thread	T000772	2
5.12	Self locking nut M20 GALV	T000255	4
5.13	Hitch	P280178	2
5.14	Bolt M20x50 8.8 GALV	T000791	4
5.15	Nut M24x2 low	T000288	2
5.16	Washer M25 GALV	T000464	2
5.17	Guide tube bolt	P280183	1
5.18	Guide tube	P280182	1
5.19	Guide tube roller	P280186	2
5.20	Grease nipple M10x1 DIN 71412-A	T000643	1
5.21	Linchpin 5*40 GALV DIN 94	T000985	1
5.22	Simple washer M20 GALV DIN 125	T000462	1
5.23	Bolt M24x80 GALV 8.8 partial thread DIN 931	T000798	1
5.24	Quick fit coupler ISO series A 12.5 M18x1.5 - euro plug	T000995	2
5.25	Plug cap IS012,5	T000488	2
5.26	Linch pin dia 25, complete with clip pin	P280197	1
5.27	Connector	P001419	1
5.28	Self locking nut M24 DIN 985	T000290	1
5.29	Simple washer M25 GALV, thin	T000464	4
5.30	All-purpose plug 42/37-038/1 LP10KR	T000981	2
5.31	Hose AA90/221/8L 2110	T000523	1

8.11. Front curtain

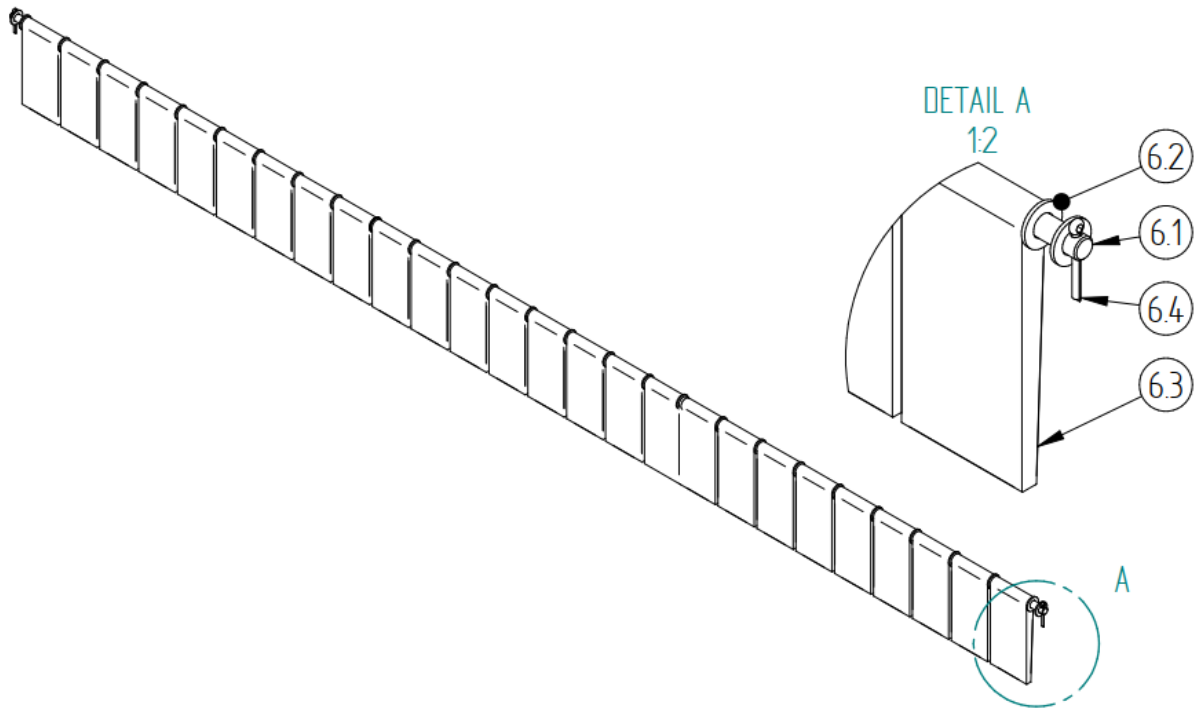

Figure 20. Front curtain

FRONT CURTAIN			
Item	Description	Index No.	Quantity
6.1	Curtain rod	L-2000	P001441
		L-2500	P001466
		L-2800	P001474
6.2	Flat washer M14 GALV	L-2000	22
		L-2500	T000459
		L-2800	27
6.3	Curtain shield	L-2000	31
		L-2500	T001931
		L-2800	21
6.4	Linch pin 5*40 GALV	T000985	26
			30
			2

8.12. Belt cover guard

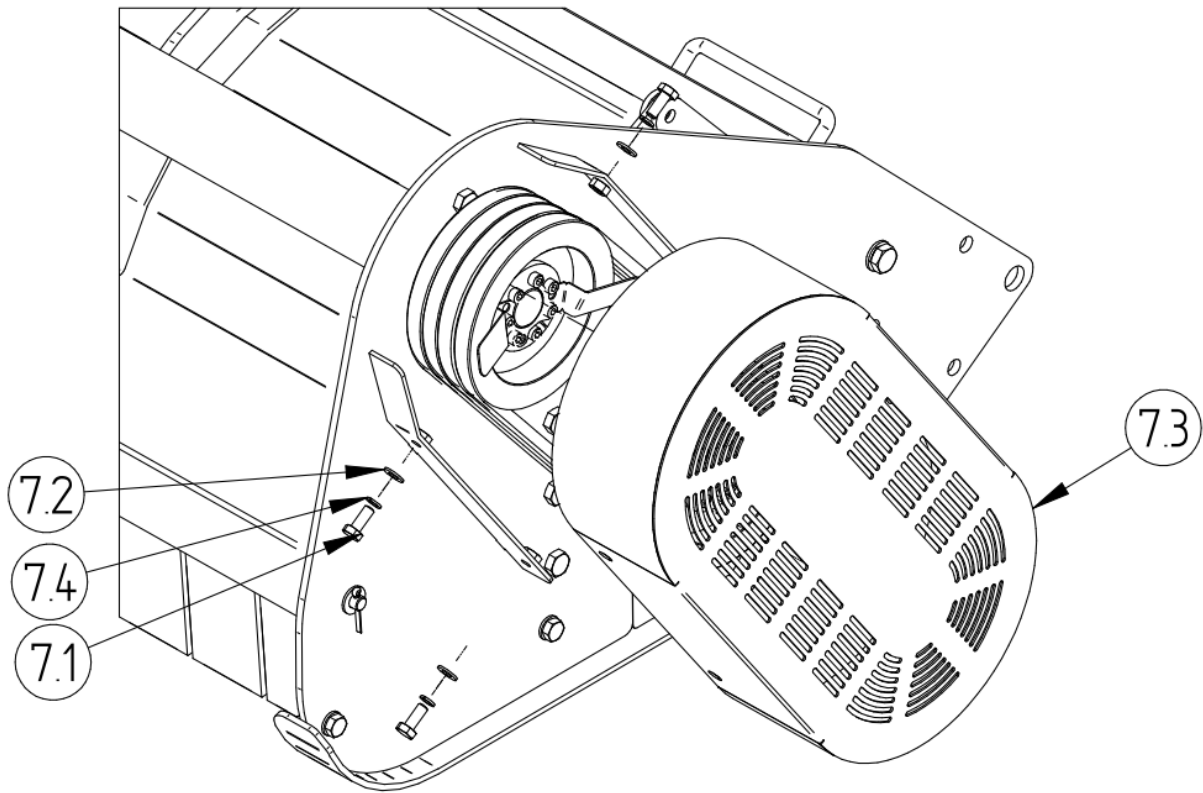

Figure 21. Belt cover guard

BELT COVER GUARD			
Item	Description	Index No.	Quantity
7.1	Bolt M10x25 GALV 8.8	T000740	4
7.2	Simple washer M10 GALV	T000456	4
7.3	Drive guard	P001483	1
7.4	Spring washer M10 GALV	T000450	4

8.13. Internal traction shaft

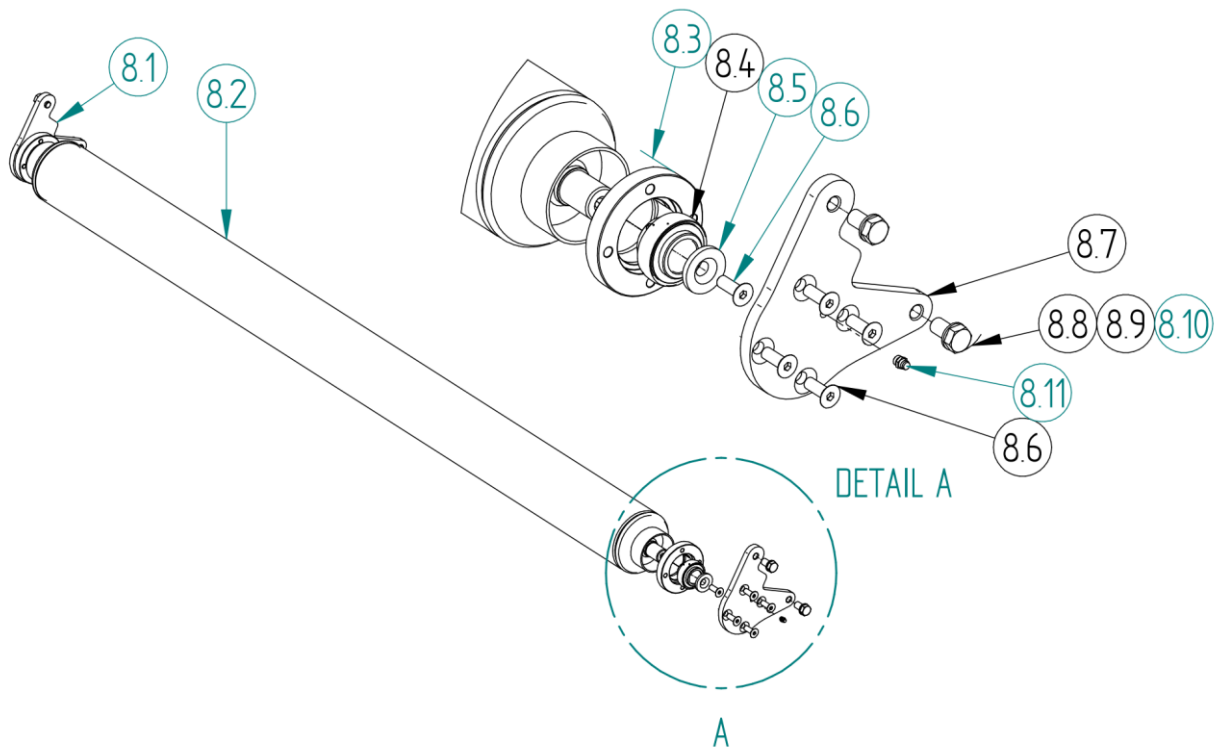

Figure 22 Traction shaft

TRACTION SHAFT			
Item	Description	Index No.	Quantity
8.1	Traction shaft fixing	P001550	1
8.2	Traction shaft	L-2000	P001499
		L-2500	P001507
		L-2800	P001515
8.3	Working shaft bearing housing	P480114	2
8.4	Bearing UC 207	T000204	2
8.5	Traction shaft stop	P001551	2
8.6	Countersunk Allen screw M12x35 GALV	T002387	10
8.7	Traction shaft fixing	P001496	1
8.8	Bolt M16x30 GALV 8.8	T000779	4
8.9	Simple washer M16 GALV	T000460	4
8.10	Spring washer M16 GALV DIN 7980	T000453	4
8.11	Grease nipple M10x1	T000643	2

8.14. External traction shaft

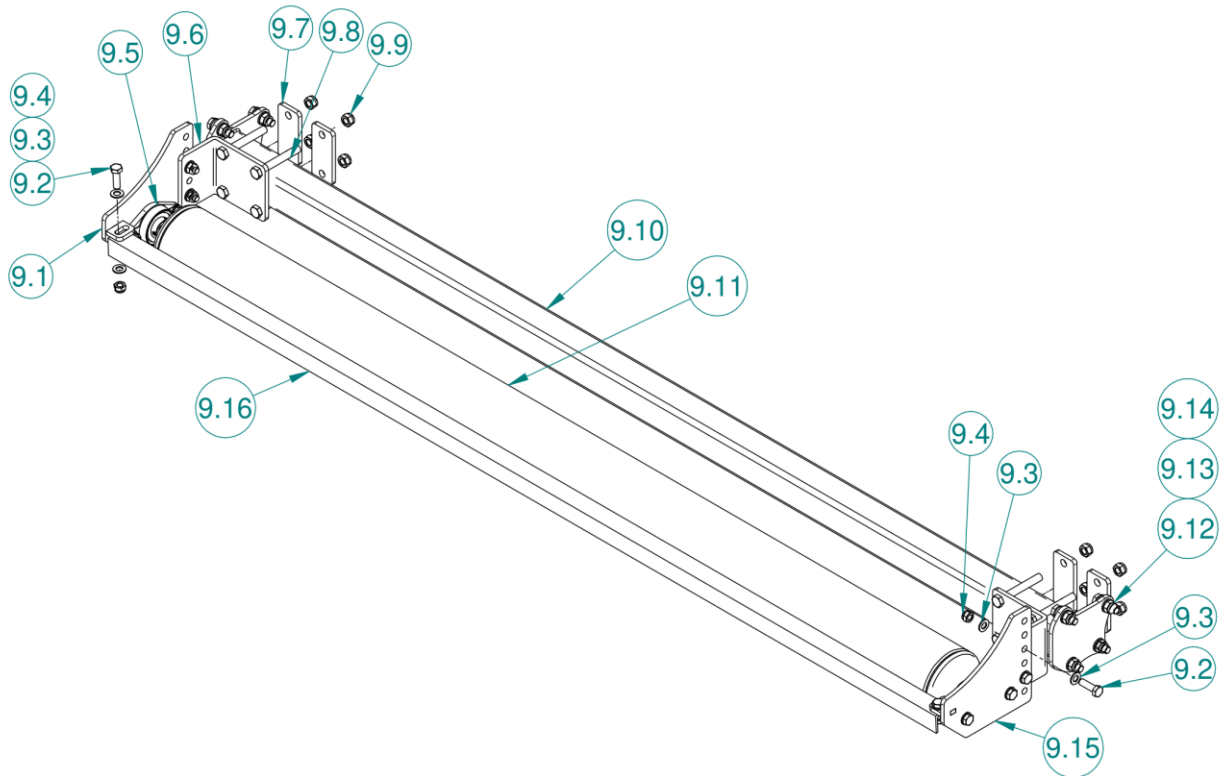

Figure 23 Traction shaft

TRACTION SHAFT				
Item	Description	Index No.	Quantity	
9.1	Shaft bracket, left	P290131	1	
9.2	Bolt M14x45 8.8 GALV	T000768	10	
9.3	Flat washer M14 GALV	T000459	20	
9.4	Self locking nut M14 GALV	T000293	10	
9.5	Bearing UCFL 207	T000186	2	
9.6	Beam bracket	P290134	2	
9.7	Fastening plate	P290135	4	
9.8	Bolt M16x120 8.8 GALV	T000774	8	
9.9	Self locking nut M16 GALV	T000294	8	
9.10	Support beam	L-2000	P001494	1
		L-2500	P001509	
		L-2800	P001517	
9.11	Traction shaft	L-2000	P260137	1
		L-2500	P290137	
		L-2800	P340137	
9.12	Bolt M16x40 GALV 8.8 full thread DIN 933	T000685	8	
9.13	Simple washer M16 GALV DIN 125	T000460	8	
9.14	Self locking nut M16 GALV 6 DIN 985	T000294	8	
9.15	Shaft bracket, right	P000951	1	
9.16	Scraper angle	L-2000	P260136	1
		L-2500	P290136	
		L-2800	P340136	

8.15. Skids

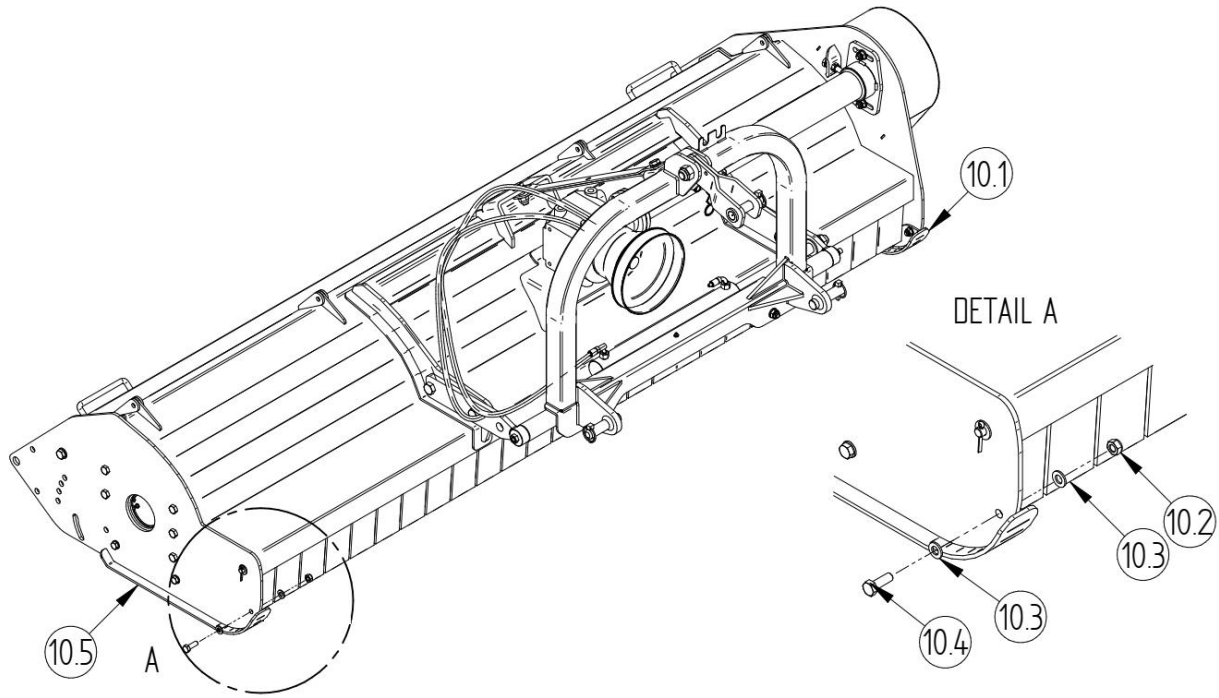

Figure 24. Skid

SKIDS			
Item	Description	Index No.	Quantity
10.1	Left skid	P001434	1
10.2	Self locking nut M12	T000291	6
10.3	Simple washer M12 GALV	T000458	12
10.4	Bolt M12x35 8.8 GALV	T000756	6
10.5	Right Skid	P001437	1



9. Warranty Card

WARRANTY CARD

Factory no.	Type
Year of manufacture	Quality Control (KJ)

Under the warranty, the manufacturer undertakes to repair, free of charge, any physical defects revealed during the warranty period, i.e. 12 months from the date of sale.

The manufacturer will be exempt from liability under the warranty in case of:

- Mechanical damage of the machine, which occurred after it was delivered to the user;
- Improper use, maintenance, storage of the machine, in particular if not compliant with the Instruction Manual;
- Execution of any repairs by unauthorized persons and without the consent of the manufacturer;
- Introducing design changes without consulting with the manufacturer;
- Transmission fitting cracks caused by the shaft run-out;

The warranty card is valid provided it has the vendor's signature and the date of sale certified with the company stamp. It must not contain deletions and amendments by unauthorized persons.

A duplicate of the warranty card may be issued upon a written request after presentation by the user of the proof of purchase.

In the case of an unjustified service call to warranty repair, the related costs will be borne by the user.

The user will file complaints within 14 days from the date of damage/defect directly to the vendor.

The manufacturer will carry out warranty repairs within 14 days from the date of the complaint.

The guarantee will be extended by the repair time counted from the date of the complaint until to the date of completion of the service if the defect prevents the use of the machine.

The warranty does not cover elements subject to natural wear, such as hydraulic hoses, plastic and rubber covers, slides, working shaft, flails, knives, copying shaft, belts, fasteners, bearings, bushings and sliding elements.

Date of sale: _____
 (Day, month, year)

 (Signature and stamp of a dealer)



WARRANTY REPAIRS RECORDS

Filled in by the manufacturer

Date of complaint claim: _____

The scope of repair and parts used: _____

Date of complaint processing: _____

Warranty extended until: _____

(signature and stamp of the service)

Date of complaint claim: _____

The scope of repair and parts used: _____

Date of complaint processing: _____

Warranty extended until: _____

(signature and stamp of the service)

Date of complaint claim: _____

The scope of repair and parts used: _____

Date of complaint processing: _____

Warranty extended until: _____

(signature and stamp of the service)

Date of complaint claim: _____

The scope of repair and parts used: _____

Date of complaint processing: _____

Warranty extended until: _____

(signature and stamp of the service)



10. Declaration of Conformity

DECLARATION OF CONFORMITY WE

1. Manufacturer of the product:

Talex Spółka z ograniczoną odpowiedzialnością
Spółka komandytowa
Ul. Dworcowa 9c
77-141 Borzytuchom

2. Product name:

All-purpose Shredder

Year of manufacture: Serial number:

3. Product classification:

PKWiU (Polish Classification of Products and Services) 29.32.15-00.90
Machines and devices for soil preparation, other

4. Intended use and application range of the product:

The All-purpose Shredder LEOPARD and LEOPARD/O is designed to destroy the remainders of plant crops and to shred the cut-down tree and shrub branches, it is perfect for mulching meadows and pastures.

5. Reference documents:

EU laws		Polish laws	
Directive No.	Title	Document name	Form
2006/42/EC	Machine directive	Ordinance of the Minister of Economy of 21 October 2006 regarding essential requirements for machines	Journal of Laws No. 199/1228

Standard No.	Title
PN-EN ISO 12100-1:2005	Machines. Safety. Basic concepts, general design principles. Part 1: Basic terminology, methodology.
PN-EN ISO 12100:2011	Safety of machinery – General principles for design – Risk assessment and risk reduction
PN-EN 14121-1:2008	Safety of machinery – Risk assessment – Part 1: Principles
PN-ISO 730-1:1996	Agricultural Wheeled Tractors – Rear-mounted three-point hitch suspension system – Categories 1, 2, 3 and 4
PN-EN ISO 4254-1:2009	Agricultural machinery – Safety – Part 1: General requirements
PN-ISO 11684:1998	Tractors, agricultural and forest machinery, powered lawn and garden equipment. Safety signs and hazard pictorials. General provisions.
PN-ISO 3600:1998	Tractors, agricultural and forest machinery, powered lawn and garden equipment – Instruction manual – Content and presentation
Quality Control (KJ) manual	Quality control manual 2012/03 Version 01
Painting manual	Painting, wet paint coats application manual 2012/02 Version 01
Welding manual	Welding manual MIG/MAG 2012/01 Version 01

Conformity with the requirements of the directives and standards has been ascertained based on the tests conducted by:
 „FITMECH” Fundacja Inżynierów i Techników Mechaników Polskich w Słupsku.
 The tests were carried out by: mgr inż. Zbigniew Myszkowski – expert of the Association of Polish Mechanical Engineers & Technicians No. 9763/11

I hereby declare, taking full responsibility, that the product conforms to the reference documents referred to in item 5.

Borzytuchom, 2 January 2013
 (place and date of issue)

 Karol Jaworski
 (name and signature of the authorised representative of the Manufacturer)